











Model 1380 Strain Gage Input Indicator Installation and Operation Manual



Dynisco Pressure Indicator NEW Model 1480	ALARM CONTACT	Transmission Output	Power supply voltage	1480 รุ่นใหม่ล่าสุด ผลิตแทนรุ่นเก่า OLD #1380, #1280
#14804100 1480-4-1-0-0	With 2 points 14804100	Volt , mA	85-264VAC	1380-2-3,1280-2-3 1380/2/3,1280/2/3
#14804100 1480-4-1-0-0	With 2 points 14804100	Volt , mA	85-264VAC	1380-1-3,1280-1-3 1380/1/3,1280/1/3
#14804100 1480-4-1-0-1	With 2 points 14804101	Volt , mA	22-65VDC	1380-2-1, 1280-2-1 1380/2/1, 1280/2-/1
#14804000 1480-4-0-0-0	With 2 points	None	85-264VAC	

TABLE OF CONTENTS

	Content	Page	Icon
1.	Quick Start Instructions	3	
2.	General	5	
3.	Notes on Safety	8	
4.	Technical Data	9	
5.	Description	13	
6.	Transport/Delivery	14	
7.	Assembly	15	
8.	Commissioning/Set Up	17	
9.	Maintenance	34	
10.	Troubleshooting	35	
11.	CE-Declaration of Conformity	38	

Dynisco Pressure Indicator NEW Model 1480	ALARM CONTACT	Transmission Output	Power supply voltage	1480 ជំហានដំបូង គំនិតការងារ OLD #1380, #1280
#14804100 1480-4-1-0-0	With 2 points 14804100	Volt, mA	85-264VAC	1380-2-3,1280-2-3 1380/2/3,1280/2/3
#14804100 1480-4-1-0-0	With 2 points 14804100	Volt, mA	85-264VAC	1380-1-3,1280-1-3 1380/1/3,1280/1/3
#14804100 1480-4-1-0-1	With 2 points 14804101	Volt, mA	22-65VDC	1380-2-1, 1280-2-1 1380/2/1, 1280/2-/1
#14804000 1480-4-0-0-0	With 2 points	None	85-264VAC	



Order Number	ALARM CONTACT	Transmitter Output	Power Supply Voltage	Input/Output
#1400400 #85-X-3-0	VERS 2 24VDC NORMALLY	VERS 24V	24V DC	RS-485 RS-485 (A/B) (2)
#1400500 #85-X-3-0-0	VERS 2 24VDC NORMALLY	VERS 24V	24V DC	RS-485 RS-485 (A/B) (2)
#1400600 #85-X-3-0-1	VERS 2 24VDC NORMALLY	VERS 24V	24V DC	RS-485 RS-485 (A/B) (2)
#1400700 #85-X-3-0-1	VERS 2 24VDC NORMALLY	VERS 24V	24V DC	RS-485 RS-485 (A/B) (2)
#1400800 #85-X-3-0-0	VERS 24VDC	VERS	24V DC	RS-485 RS-485 (A/B) (2)

1. MODEL 1380 QUICK START INSTRUCTIONS

1.1	Mounting	3
1.2	Wiring	3
1.3	Scaling	3
1.4	Calibration and Operation	4

1.1 MOUNTING

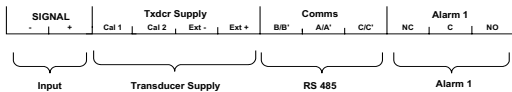
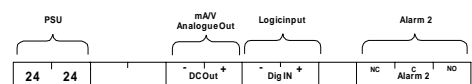
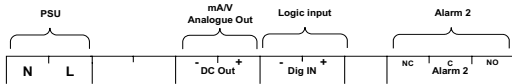
- Prepare panel cutout to specified dimensions.
- Slide case through cutout and install mounting clips over case ends, engaging the detents in the case. Slide mounting clips fully forward (with the “y” side toward the front) until base is secure in panel.

1.2 WIRING

- Connect wires from cable to terminals as indicated below.
- Connect AC or AC/DC power as indicated in diagram. Note power type is dependent on model number.
- If applicable, connect alarm(s). Note that alarm defaults are High, Reverse Acting.

Universal Power Supply (85 - 264 Vac)
1380-X-3

24 V (dc or ac)
1380-X-1



1.3 SCALING

- Slide instrument out of case. While pressing the **FUNC** button, insert instrument back into case, continue to hold **FUNC** button until **ConF** is displayed.
- Press **FUNC** once, then use the ▲ ▼ buttons to modify the units.
- Press **FUNC** to modify the decimal point.
- Press **FUNC**, display will read F.S.U. (Full Scale Value).

GENERAL



- Using the Up and Down arrow keys, select the value that matched the full scale of the transducer. Enter with **FUNC** key. (If your transducer was purchased in Asia, it is preset at 70.0 MPa, and adjustment may not be necessary).
- Press and hold **FUNC** until display returns to pressure reading.
- Secure the instrument in the case by pushing firmly in the bezel until it clicks into the retaining tabs.

1.4 CALIBRATION AND OPERATION

- When power is applied the display will read 1380, then the software version and then the pressure reading. At this point, be sure that no pressure is applied and that the transducer is at operating temperature.
- Press the **FUNC** key and the legend **LO.OFF** appears. Using the Up arrow key, advance the legend to **LO.ON**.
- Press the **FUNC** key to initialize zero calibration. After approximately 5 seconds, the legend **F.U.S.C.** will appear and alternate with the full scale value.
- Press the Up arrow key to advance to the legend **FU ON**. Using the **FUNC** key, initiate the full scale calibration. After 5 seconds, the indicator will read 0 ± 10 .
- Press the **FUNC** key until, **1.HAr** is displayed and alternates between alarm set-point. Use the up and down arrow keys to set the appropriate alarm set-point.
- Press the **FUNC** key until, **2.HAr** is displayed and repeat for second alarm set-point.
- Press the **FUNC** key to return to pressure display.
- The system is now ready for use.

Dynisco Pressure Indicator NEW Model 1480	ALARM CONTACT	Transmission Output	Power supply voltage	1480 รุ่นใหม่ล่าสุด ผลิตภัณฑ์รุ่นเก่า OLD #1380, #1280
#14804100 1480-4-1-0-0	With 2 points 14804100	Volt , mA	85-264VAC	1380-2-3,1280-2-3 1380/2/3,1280/2/3
#14804100 1480-4-1-0-0	With 2 points 14804100	Volt , mA	85-264VAC	1380-1-3,1280-1-3 1380/1/3,1280/1/3
#14804100 1480-4-1-0-1	With 2 points 14804101	Volt , mA	22-65VDC	1380-2-1, 1280-2-1 1380/2/1, 1280/2-/1
#14804000 1480-4-0-0-0	With 2 points	None	85-264VAC	



2. GENERAL

2.1	Important Information	5
2.2	Copyright	5
2.3	Explanation of Icons	5
2.4	Abbreviations	6
2.5	Features	6
2.6	User's Obligations	6

2.1 IMPORTANT INFORMATION

This manual applies to the 1380 series of indicators only. It must be kept near the equipment in a readily and immediately accessible location at all times. The content of this manual must be read, understood and followed in its entirety. This applies in particular to the notes on safety. Following the safety instructions will help to prevent accidents, defects and malfunctions.

DYNISCO will not be held liable for any injury, loss or damage resulting from failure to follow the instructions in this manual.

If product malfunctions, in spite of having followed the operating instructions, please contact the **DYNISCO** customer service department (See the back of the manual for contact information).

2.2 COPYRIGHT

It is strictly forbidden to allow reproduction of any kind “in whole or in part” to persons outside of Dynisco without Dynisco’s consent.

2.3 EXPLANATION OF ICONS

The manual uses icons to indicate information pertaining to safety:

ATTENTION Risk of destruction or damage to equipment, machines or installations



General danger to life or limb

Dynisco Pressure Indicator NEW Model 1480	ALARM CONTACT	Transmission Output	Power supply voltage	1480 តំបន់បង្ហាញ នៃគីឡូញ៉ាតូ OLD #1380, #1280
#14804100 1480-4-1-0-0	With 2 points 14804100	Volt, mA	85-264VAC	1380-2-3/1280-2-3 1380/2/3/1280/2/3
#14804100 1480-4-1-0-0	With 2 points 14804100	Volt, mA	85-264VAC	1380-1-3/1280-1-3 1380/1/3/1280/1/3
#14804100 1480-4-1-0-1	With 2 points 14804101	Volt, mA	22-65VDC	1380-2-1, 1280-2-1 1380/2/1, 1280/2-1
#14804000 1480-4-0-0-0	With 2 points	None	05-264VAC	



Specific danger to life or limb



You **MUST** do this

The safety instructions are provided again in the individual chapters of the manual.

2.4 ABBREVIATIONS

The following abbreviations are used:

OM	Operating Manual
F.S.U	Full Scale Value
PT	Pressure Transducer

2.5 FEATURES

- A peak reading display (high and low) selected from the front panel.
- A digital filter to reduce the effects of input variations on the display, analog output and alarms.
- Input interruption sensing to detect when a transducer or any one of its leads has been disconnected.
- A program lockout feature that disables the front keyboard to prevent unauthorized or accidental changes.
- A digital input that can be configured for either resetting the alarms or triggering hold on value.
- A digital display that provides operator prompts with messages to show current status or errors.
- A compact, 48 mm x 96 mm (1.89" x 3.78"), 1/8 DIN enclosure that projects only 89.5 mm (3.52") behind the panel.

2.6 USER'S OBLIGATIONS

The operator or owner of the larger overall system, e.g. a machine, is responsible for following the safety and accident prevention regulations that apply to the specific application.

3. NOTES ON SAFETY



The operator or owner of the larger overall system is responsible for following the safety and accident prevention regulations that apply to the specific application.

Warnings



Electrical shock can result in death or serious injury. Avoid contact with the leads and terminals. High voltage that may be present on leads can cause electrical shock.

Mounting and electrical connection of the PT and the 1380 must be done by specialists with EMC training, following all applicable regulations.

The 1380 series of pressure indicators can be used in ambient temperatures up to 55°C.

Higher temperature can result in damage and malfunction. Do not install the indicator in places where this temperature is exceeded.

DYNISCO will not be held liable for any injury, loss or damage resulting from failure to follow the instructions in this manual.

Permanently Connected Equipment

A disconnectable device must be fitted with one of the following items:

- a) a switch or circuit breaker shall be included in the building installation
- b) it shall be in close proximity to the equipment and within easy reach of the OPERATOR
- c) it shall be marked as the disconnecting device for the equipment.



4. TECHNICAL DATA

4.1	Ordering Guide for 1380	8
4.2	Specifications	8
4.2.1	General	8
4.2.2	Strain Gage Input	9
4.2.3	Special Features	10
4.2.4	Alarms	10
4.2.5	Analog Retransmission	11
4.2.6	Logic Input	11

4.1 ORDERING GUIDE FOR 1380

1380-1-1	Dual Alarms with a 24 Vdc Power Supply
1380-2-1	Dual Alarms and Analog Retrains with a 24 Vdc Power Supply
1380-1-3	Dual Alarms with a 85 - 264 Vac Power Supply
1380-2-3	Dual Alarms and Analog Retrains with a 85 - 264 Vac Power Supply

4.2 SPECIFICATIONS

4.2.1 GENERAL

Protection Rating	VO Rated fire retardant material Bezel designed and tested IP65 compliant for indoor locations Sleeve IP20 compliant Terminal block IP20 compliant Installation designed for be IP65 compliant when specified gasket is used
Dimensions	48 mm high x 96 mm wide x 99.3 mm deep (1.89" high x 3.78" wide x 3.9" deep) 1/8 DIN per DIN 43700 Less than 105 mm depth from front of panel
Installation	Panel mounted, secured by 2 mounting clips
Cut-out	45 mm high x 92 mm wide, + 0.8 mm/-0 mm (1.77" high x 3.62" wide, +0.03"/-0")
Rear Terminal Block	24 screw terminals with safety covers
Display	4 red LED digits (for pressure display), 13.2 mm high 7 segments plus decimal point
Indicators	4 amber LEDs for unit indication 2 red LEDs for alarm annunciator function



Keyboard	Four domed buttons
Sample Rate	100 mS
Common Mode Rejection	Minimum 120 dB at 50 or 60 Hz
Normal Mode Rejection	60 dB at 50 or 60 Hz
Accuracy	+/- 0.1% of FSV with Shunt Cal
Temperature Drift	Less than 100 ppm/deg C of FSV
Power Supply Options	85 - 264 Vac or 24 V(ac or dc) - 15% + 20%
Operating Altitude	up to 2000 meters
Operating Temperature Range	0 - 55°C
Storage Temperature	-30°C to 70°C
Operating Humidity Range	5 - 85% RH non-condensing
Vibration	10 to 150 Hz at a peak of 1G
Inter Unit Spacing	The recommended minimum spacing between controllers shown here should not be reduced to allow sufficient natural air flow 1.5" (38mm).
Cable size	For supply connections use 16AWG or larger wires rated for at least 75°C Use copper conductors only. For 24V the polarity is not important. It is the Users responsibility to provide an external fuse or circuit breaker.
Input Protection	Internal thermister Fusing For 85/265Vac fuse type T rated 1A 250V For 24 V ac/dc fuse type T rated 4A 250V

4.2.2 STRAIN GAGE INPUT

Input	350 Ohm Strain Gage
Bridge Connection	4 or 6 wire (6 to use internal shunt cal switch)
Bridge Excitation	10 V +/- 7%



Bridge Sensitivity	1.4 - 4 mV/V
Input Signal Span	- 25% to +125% of full scale (approximately -10 mV to +50 mV)
Calibration	Internal switch between CAL2 & CAL1 terminals. External resistor only.
Shunt Value	From 40% to 100%
Zero Balance	+/- 25% of FSV
Tare	+/- 25% of FSV
Readout	Keyboard programmable from 10 to 9,990
Input Resolution	Adjustable by 1 up to 2010 Adjustable by 10 from 2010 to 20100 Adjustable by 100 up to 9,990 Decimal point may be set in any position
Open Circuit Detection	On any of the four transducer leads selectable up or down scale fault mode. By internal 1.33 MOhm pull down resistors to EXT - on both Sig + and Sig - terminals.
50/60 Hz Line Filter	Universal 50 & 60 Hz rejection filter (no requirement to set line frequency).
Cable Impedence	No errors due to cables if the two power supplying cables are matched
Isolation	Isolated from all other I/O circuits up to 300 V RMS. Measurement category: CAT II.

4.2.3 SPECIAL FEATURES

Display Filter	First order digital filter on displayed value with configurable time constant of 0.4, 1, 2, 3, 4 or 5 seconds.
Peak Detection	Automatic detection of maximum and minimum measured value.

4.2.4 ALARMS

Quantity	Two independent alarm output relays of type SPDT Form C
Contacts	For each relay common, NC and NO contact are permanently available at the designated terminal.



Contact Rating	0.6A @110 Vdc resistive load 0.5A @ 220 Vdc resistive load 0.3A @ 110 Vdc inductive load
Alarm Update Time	100 mS
Alarm Filter	Optional digital filter using same time constant as selected for the display filter

4.2.5 ANALOG RETRANSMISSION

Output Types	0 - 20 mA or 4 - 20 mA, maximum load 500 Ohms 0 - 5 Vdc or 0 - 10 Vdc Software Selectable
Open Circuit Voltage	Less than 25 Vdc
Resolution	11 bit (0.05% of full 20 mA span i.e. 10 uA)
Calibration Accuracy	Better than 0.2% of reading +/- 20 uA Better than 0.2% of reading +/- 10 mV
Linearity Error	Less than 0.3% of reading
Filter	Configurable digital filter on output value using same time constant as display filter
Temperature Drift	Less than 100 ppm/deg C (plus input drift)
Output Noise	Within DC to 5 Hz measurement bandwidth - less than resolution (i.e. < 10 uA)
Update Time	100 mS

4.2.6 LOGIC INPUT

Input Type	Voltage free contact
Source Current	12 mA
Closed State	< 200 Ohms
Open State	> 600 Ohms
Isolation	Not isolated from instrument and all other I/O circuits.



5. DESCRIPTION

The Dynisco model 1380 Strain Gage Indicator is a flexible, programmable indicator designed for 350 Ohm strain gage based sensors, such as pressure transducers and load cells. The four digit, 0.52" LED display provides a precise, readable indication of the measured value.

You can program the 1380 to display in various engineering units up to a Full Scale Value (F.S.U.) of 9,990 with an accuracy of $\pm 0.1\%$. The span value, alarm set points and other constants are stored indefinitely in non-volatile memory. Easy-to-remember pushbutton sequences simplify transducer calibration routines.

Two independent SPDT alarm relays are a standard feature of the 1380. The dual high or low set points are easily programmed from the front keyboard and are displayed on the digital display. The low alarms can be set as low alarm masked to inhibit alarm action during start up. Relay contacts are provided to activate an annunciator or to initiate automatic shutdown if operating conditions exceed preset limits.

A programmable voltage to current retransmission output is available as an option. You can select a voltage output of 0 - 5 Vdc or 0 - 10 Vdc or current outputs of 4 - 20 mA or 0 - 20 mA to drive chart recorders or data acquisition equipment.



6. TRANSPORT/DELIVERY

6.1	Transport/Packing/Transport Damage	13
6.2	Storage	13
6.3	Scope of Delivery	13

6.1 TRANSPORT/PACKING/TRANSPORT DAMAGE

- Do not let the indicator be damaged by other items during transit.
- Use only the original packaging.
- Report transport damage to **DYNISCO** immediately in writing.

6.2 STORAGE

- Store the indicator in original packaging only.
- Protect against dust and moisture.

6.3 SCOPE OF DELIVERY

- Indicator
- Two mounting clips
- Operating manual with declaration of conformity

Dynisco Pressure Indicator NEW Model 1480	ALARM CONTACT	Transmission Output	Power supply voltage	1480 รุ่นใหม่ล่าสุด ผลิตแทนรุ่นเก่า OLD #1380, #1280
#14804100 1480-4-1-0-0	With 2 points 14804100	Volt , mA	85-264VAC	1380-2-3,1280-2-3 1380/2/3,1280/2/3
#14804100 1480-4-1-0-0	With 2 points 14804100	Volt , mA	85-264VAC	1380-1-3,1280-1-3 1380/1/3,1280/1/3
#14804100 1480-4-1-0-0	With 2 points 14804101	Volt , mA	22-65VDC	1380-2-1, 1280-2-1 1380/2/1, 1280/2-/1
#14804000 1480-4-0-0-0	With 2 points	None	85-264VAC	



7. INSTALLATION

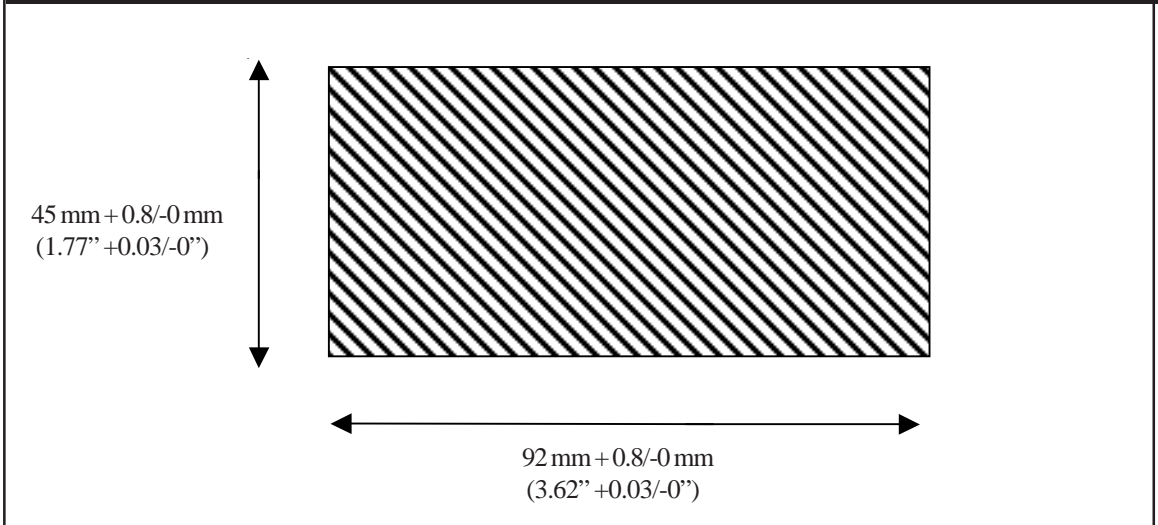
7.1	Unpacking	14
7.1	Mounting	14

7.1 UNPACKING

Inspect the package for shipping damage. If you notice an damage, notify the freight carrier immediately.

7.2 MOUNTING

Fig. 7-1 Panel Cutout



- Make the instrument panel cut-out with the specified cut out dimensions.
- Remove the unit from the instrument case. By spreading the two tabs on the front panel, then grasp the bezel and pull.
- Slide the instrument case through the cutout.
- Slide the panel clips from the rear over the instrument case so that the snap-in elements of the mounting frame engage in the recesses on the sides.
- Push clips toward the panel until firmly mounted.
- Slide the instrument from the front into the instrument case.
- Secure the instrument in the case by pushing firmly in the bezel until it clicks into the retaining tabs.



Fig. 7-2 Side View with Mounting Clip



Dynisco Pressure Indicator NEW Model 1480	ALARM CONTACT	Transmission Output	Power supply voltage	1480 รุ่นใหม่ล่าสุด มีคุณสมบัติเก่า OLD #1380, #1280
#14804100 1480-4-1-0-0	With 2 points 14804100	Volt , mA	85-264VAC	1380-2-3,1280-2-3 1380/2/3,1280/2/3
#14804100 1480-4-1-0-0	With 2 points 14804100	Volt , mA	85-264VAC	1380-1-3,1280-1-3 1380/1/3,1280/1/3
#14804100 1480-4-1-0-0	With 2 points 14804101	Volt , mA	22-65VDC	1380-2-1, 1280-2-1 1380/2/1, 1280/2-/1
#14804000 1480-4-0-0-0	With 2 points	None	85-264VAC	



8. COMMISSIONING

8.1	Set Up	16
8.1.1	Front Panel	16
8.1.2	Push Button Functions	17
8.1.3	Rear Terminal Connections	17
8.1.4	Input Wiring	20
8.1.5	Configuration/Calibration Mode	20
8.1.6	Configurable Parameters	21
8.1.7	Analog Output Calibration	25
8.2	Operating Mode	26
8.2.1	Keyboard Lock/Unlock	26
8.2.2	Transducer Input Calibration	26
8.2.3	Alarm Set Points	27
8.2.4	Alarm Reset Function	28
8.2.5	Peak Hold Function	28
8.3	Default Data Loading Procedure	29
8.3.1	Default Data for Configuration Parameters	30
8.3.2	Default Data for Operating Parameters	30
8.3.3	Default Data for Calibration Parameters	31

8.1 SET UP

8.1.1 FRONT PANEL

The front of the Model 1380 is shown in Figure 7.1. Key items on the front panel are:

- A four digit LED display (for measurement), five digit LED display for configuration protocol
- LED indicators AL1 (Alarm 1) and AL2 (Alarm 2)
- LED indicator REM (Remote Status)
- Four domed buttons labeled Reset, ▲, ▼, Func. The pushbutton functions are listed in the table below.
- LED indicators for pressure indicators kgf/cm², PSI, BAR, MPa.

Fig. 8-1 Front Panel



8.1.2 PUSHBUTTON FUNCTIONS

Button Sequence	Resulting Operation
▼	Used to step between choices or to decrement a parameter value
▲	Used to step between choices, increment a parameter value or to display peak high or peak low
FUNC	Used to store currently displayed parameter value, as modified and to display the next parameter, held in during power up for configuration mode and held in to exit configuration mode
RESET	Used to scroll back to the previous parameter without storing the modified parameter value
RESET + ▼ or RESET + ▲	Alarm manual reset (either button sequence will reset both alarms)
RESET + FUNC	Reset peak high and peak low values
▼ + ▲	Initiate default data loading procedure
▼ + RESET + FUNC	Used to lock or unlock keyboard for transducer calibration and parameter modification

To perform operations requiring two or more pushbuttons, press and hold the first pushbutton, then press and hold the second pushbutton, and then press the third pushbutton, if required.

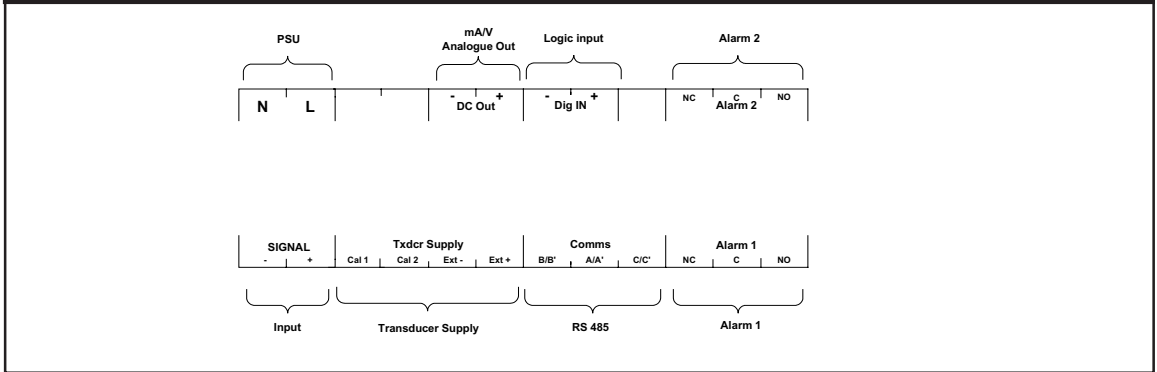
Note: You must follow the pushbutton sequences exactly as described.

8.1.3 REAR TERMINAL CONNECTIONS

The electrical connections for the Model 1380 is shown below. The layout of the terminals, is depicted from the rear.

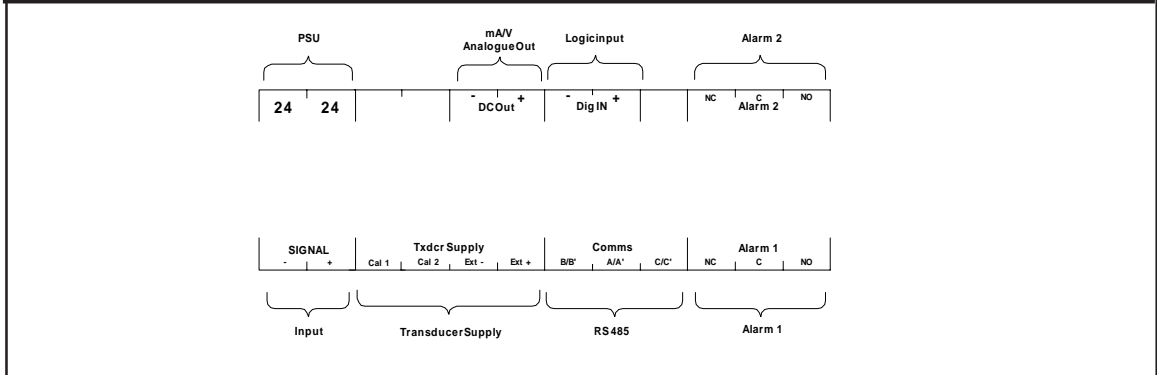


Fig. 8-2 Rear Terminal Locations (85 - 264 Vac)



COMMISSIONING

Fig. 8-3 Rear Terminal Locations (24 V ac or dc)



Dynisco Pressure Indicator NEW Model 1480	ALARM CONTACT	Transmission Output	Power supply voltage	1480 รุ่นใหม่ล่าสุด ผลิตแทนรุ่นเก่า OLD #1380, #1280
#14804100 1480-4-1-0-0	With 2 points 14804100	Volt , mA	85-264VAC	1380-2-3,1280-2-3 1380/2/3,1280/2/3
#14804100 1480-4-1-0-0	With 2 points 14804100	Volt , mA	85-264VAC	1380-1-3,1280-1-3 1380/1/3,1280/1/3
#14804100 1480-4-1-0-0	With 2 points 14804101	Volt , mA	22-65VDC	1380-2-1, 1280-2-1 1380/2/1, 1280/2-/1
#14804000 1480-4-0-0-0	With 2 points	None	85-264VAC	

Fig. 8-4 1290 to 1380 Wiring Conversion Table

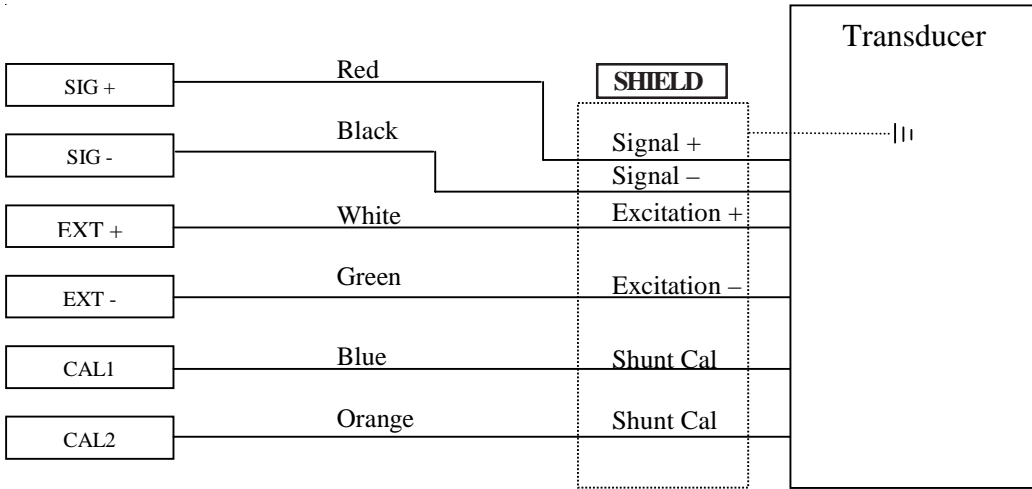
<u>Terminal</u>	<u>1290 Connection</u>	<u>1380 Connection</u>	<u>Dynisco Transducer Cable Color Code</u>
1	Signal +	Signal +	Red
3	Signal -	Signal -	Black
4	Exc +	Ext +	White
5	Exc -	Ext -	Green
5	Cal1	Cal1	ie
6	Cal2	Cal2	Orange
7	Logic Input	Dig In +	
8	Logic Input	Dig In -	
9	100/240 VAC	L (Line)	
10	LN (Neutral)	N (Neutral)	
11	Ground	No Connection	
12	AL2	Alarm 2 N.O or N.C	
13	AL2 C	Alarm 2 C	
14	AL1	Alarm 1 N.O or N.C	
15	AL1 C	Alarm 1 C	
18	Remote Enable	N/A	
19	Remote Enable	N/A	
20	A/A'	N/A	
21	B/B' / mA V+	N/A	
22	C/C' / mA V-	N/A	



8.1.4 INPUT WIRING

Connect the pressure transducer per the instructions below. Do not run the input wires in the same bundle with the power cables; instead, shielded cable should be used and grounded at the transducer end only (Dynisco’s cable assembly provides this grounding).

COMMISSIONING



Dynisco Standard Wiring Code

Lead	Color
Excitation +	White
Signal +	Red
Excitation -	Green
Signal -	Black
Calibration 1	Blue
Calibration 2	Orange

Transducer Pin Out

PT420 Series	PT460 Series
A	C
B	A
C	D
D	B
E	E
F	F
G (Unused)	
H (Unused)	

8.1.5 CONFIGURATION/CALIBRATION MODE

To enter configuration mode, hold the **FUNC** button while powering the unit on until **ConF** is displayed. A list of all configurable parameters starts below.

Press **FUNC** to initiate the configuration procedure, starting at the first parameter.

Press **RESET** to initiate the configuration procedure, starting with the last parameter.

Press **▲** to toggle the display from **ConF** to **CAL**, initiating output calibration mode, if required.

For each parameter you will either select one of several choices or enter a numerical value.



Press ▲ to modify or change the parameter or increase the number displayed.
Press ▼ to modify or change the parameter or decrease the number displayed.
Press **FUNC** to save your changes and step to the next parameter.
Press **RESET** to step to the previous parameter without saving your changes.

For many parameter settings, the display initially alternates between a code and numerical value. Once you start to modify the value, however, only the numerical value will be shown.

When entering a numerical value, ▲ and ▼ are used to increase or decrease the number being entered. The change in value for each step is 1, 10, or 100, depending on the size of the number. The increment is 1 for values up to 2010, 10 from 2010 to 9990.

8.1.6 CONFIGURABLE PARAMETERS

The following is the complete sequence of configurable parameters. Default values are given on page 30.

A. DISPLAY UNITS

The display shows Un followed by:

PSI = psi
BAR = bar
nPA = MPa
Cn2 = kgf/cm²
OFF = None

B. DECIMAL POINT POSITION

The display shows:

---- for no digits after the decimal point
----. for one digit after the decimal point
---. for two digits after the decimal point
--. for three digits after the decimal point



B1. FULL SCALE READOUT

The display alternates between **F.S.U.** (Full Scale Value) and a numerical value from 10 to 9990. Only the numerical value will be shown during modification. This value **MUST** be set equal to the sensor full range, e.g. 70.0 MPa

C. DISPLAY FILTER TIME CONSTANT

The display shows **F.T.C.** (Filter Time Constant) followed by:

- .4** for 400 millisecond filter time constant
- 1** for 1 second filter time constant
- 2** for 2 second filter time constant
- 3** for 3 second filter time constant
- 4** for 4 second filter time constant
- 5** for 5 second filter time constant

D. INPUT INTERRUPT

The display shows **I.F.S.** (Input Fail Safe) followed by:

- Hi** for up scale fail mode, or
- Lo** for down scale fail mode

E. SHUNT CALIBRATION

The display shows **S.C.** (Shunt Calibration) followed by:

- On** for shunt calibration enabled, or
 - OFF** for shunt calibration disabled
- Note:** Set shunt calibration to **On** when using Dynisco transducers.

This function is used to check to see if the indicator is set up correctly.

E1. SHUNT CALIBRATION VALUE

This step is skipped if the shunt calibration is **OFF**. The display alternately shows **Shunt** and a numerical value from 40.0 to 100.0, but only the numerical value will be shown during modification. This value corresponds to the percentage of the Full Scale Value.

Note: When using Dynisco transducers, the Shunt Calibration value should be set to 80.0.



F. EXTERNAL CONTACT FUNCTION

The display shows **E.C.** (External Contact) followed by:

nr to enable external contact for manual alarm reset, via rear digital input terminals or
Ho to enable external contact for hold-on-value sampling

F1. CONTACT STATUS

The display shows **C.S.** (Contact Status) followed by:

CL if function selected above is performed with contact closed, or
OP if function selected above is performed with contact open.

G. ALARM 1 OPERATIVE MODE

The display shows **A1** (Alarm 1) followed by:

HA High alarm with automatic reset
HL High alarm with manual reset (High Latched Alarm)
LA Low alarm with automatic reset
LL Low alarm with manual reset (Low Latched Alarm)
OFF for no alarm 1

G1. ALARM 1 ACTION

This step is skipped if Alarm 1 if **OFF**.

The display shows **A1** (Alarm 1) followed by:

rEU for relay energized if no alarm condition (reverse action/fail safe), or
dir for relay energized if alarm condition (direct action).

G2. ALARM 1 MASKING OPTION

This step is skipped if Alarm 1 of **OFF** or **HIGH**.

The display shows **A1** (Alarm 1) followed by:

dIS for masking option disabled, or
Enb for masking option enabled.

This function masks low alarm conditions during start-up until the measured value first becomes greater than the alarm threshold plus hysteresis. The alarm must have been programmed as a low alarm.



G3. ALARM 1 FILTER

This step is skipped if alarm 1 is **OFF**.

The display shows **F1** (Filter) followed by:

OFF for no filter on alarm threshold, or
xxx for filter with the time constant chosen in step C above.

G4. ALARM 1 HYSTERESIS

This step is skipped if alarm is **OFF**.

The display shows **H1** (Hysteresis 1) followed by a value from 0.1 to 9.9. This value corresponds to the percentage of the Full Scale Value.

H. ALARM 2

Follow the same procedure as in steps G-G4 above.

L. ANALOG RETRANSMISSION (OPTION)

Note: The indicator skips step L1 to L3 if analog retransmission is NOT implemented.

The display shows **AO** (Analog Output) followed by:

0.20 for 0 – 20 mA

4.20 for 4 – 20 mA

0.10 for 0 – 10 V

0.5 for 0 - 5 V

OFF for retransmission disabled

L1. ANALOG RETRANSMISSION SCALING: LOW SCALE VALUE

The display alternately shows **Ar.L.S.U.** (Analog Retransmission Low Scale Value) and a numerical value. This parameter establishes the lower limit for the analog output; only the numerical value is shown during modification. Resolution and decimal point position are as selected for the readout value.



L2. ANALOG RETRANSMISSION SCALING: FULL SCALE VALUE

The display alternately shows **Ar.F.S.U.** (Analog Retransmission Full Scale Value) and a numerical value. This parameter establishes the upper limit for the analog output; only the numerical value is shown during modification. Resolution and decimal position are as selected for the readout value.

L3. ANALOG RETRANSMISSION FILTER

The display shows **rF** followed by:

OFF for no filter on retransmitted value, or
xxx for filter having the time constant chosen in step C.

Press **FUNC** to lock in the parameter.

At this point the configuration procedure is complete and the display will return to showing **CO nF**.

If necessary, you may now select the analog output calibration procedure by pressing **▲**. Refer to Analog Output Calibration, below.

When configuration/calibration is complete, press and hold the FUNC button and continue to hold until the unit returns to PV display.

8.1.7 ANALOG OUTPUT CALIBRATION

Press **▲** to toggle the display from **CO nF** to **CAL**, initiating output calibration mode.
Press **FUNC** to initiate the calibration procedure, starting at the first parameter.
Press **RESET** to initiate the calibration procedure, starting at the last parameter.

Perform the calibration procedure in accordance with the config settings to select:

- Current Output, calibration parameters C6 and C7
- Voltage Output, calibration parameters C8 and C9

When the display shows **CAL**, you can also load the default parameters, as shown on page 31.

To calibrate the analog retransmission output, connect a multimeter, set to the proper measurement range, to terminals DC out + and - . Press the **FUNC** button to reach desired parameter then make output adjustments by pressing **▲** or **▼** until the signal output measured by the multimeter reaches the proper value. The display only shows the number of counts for the digital to analog converter.

C6 - Retransmission current output minimum value - adjust to 50.0 uA (near zero)

C7 - Retransmission current output minimum value - adjust to 20.0 mA



- C8 - Retransmission current output minimum value - adjust to 0.00 Vdc
- C9 - Retransmission current output minimum value - adjust to 10.00 Vdc

Note: The above procedure only applies to indicators order with the output option. Units are precalibrated from the factory and do not require adjustment.

8.2 OPERATING MODE

In this mode the Model 1380 monitors the input signal, displays the measured value, and performs alarm functions. You can display high and low peak values, lock and unlock the keyboard, reset alarms, and perform transducer input calibration and alarm threshold settings. It is also possible to load default parameters.

Parameter values listed below can always be viewed, but they can only be modified if the indicator keyboard is unlocked. If anyone attempts to modify the parameters when the indicator is locked, the display will show **inh**.

8.2.1 KEYBOARD LOCK/UNLOCK

When the measured value is displayed (normal operating mode), you can lock or unlock the keyboard by holding down the buttons in the following order, **▼ + RESET + FUNC**. The display will then show the new desired mode: **Loc** or **UnLoc**.

8.2.2 TRANSDUCER INPUT CALIBRATION

You can modify the operating parameters and load default data only when the instrument is unlocked and in local mode. Default values are shown on page 29 .

Notes:

1. Transducer/Indicator calibration should be performed with the transducer at operating temperature, and with no pressure applied.
2. The Zero and Full Scale calibrations should be done concurrently.

1. ZERO TRANSDUCER CALIBRATION

Press **FUNC** to enter the calibration mode

The display will show **LO.OFF**

Press the **▲** button once

The display will show **LO.On**

Press the **FUNC** button to perform the zero calibration

The display will blank except for 5 decimal points

After a brief "time out" the unit will enter full scale calibration



Note: In lieu of the ▲ button, pressing the **FUNC** button will advance the indicator to the next parameter.

2. FULL SCALE TRANSDUCER CALIBRATION

The display alternates between **FU.S.C.** and the value of full scale in engineering units.

Press the ▲ button once

The display will show **FU.On**

Press the **FUNC** button to perform the full scale calibration

The indicator automatically returns to operating mode after 6 seconds if no changes are made.

3. TARE CALIBRATION (WEIGHT APPLICATIONS ONLY)

The display alternates between **tArE** and the value of the tare in engineering units. The tare will be forced to zero whenever zero or full scale calibration is performed. At this point there are two options:

a. To perform calibration press ▲

The display will show **tA**. Followed by:

OFF to disable calibration

ON to enable calibration

b. If calibration is not needed, press **FUNC** to go to the next parameter. The instrument automatically returns to operating mode after 6 seconds if no changes are made.

8.2.3 ALARM SET POINTS

If the indicator has automatically returned to operating mode you can return to set the alarms by following the procedure.

1. ALARM 1

Press the **FUNC** key four times. The display will alternately show **1.xxxx** and the alarm set point, where **xxxx** is a code for alarm operation mode. Only the alarm set point is shown during modification. Use the ▲ and ▼ keys to modify this parameter. Resolution and decimal point position are as selected for the readout value. Press **FUNC** to store your change. The indicator automatically returns to the normal operating mode after 6 seconds if no changes are made.

The codes for the remaining digits in the alarm-operating mode are:



2nd Digit

H = High Alarm

L = Low Alarm

3rd Digit

A = Automatic reset

n = Manual reset

4th Digit

d = Direct action

r = Reverse action

5th Digit

n = Low alarm mask

blank = Not masked

For example, a display of **1.HAr** would indicate High alarm, automatic reset, reverse action.

2. ALARM 2

The indicator will automatically enter this parameter after the **FUNC** key is pressed to store the Alarm 1 set point. To enter Alarm 2 from the normal operating mode, press **FUNC** five times. Programming the Alarm 2 set point is the same as Alarm 1 above, except that the display alternately shows **2.xxxx** and the alarm value.

8.2.4 ALARM RESET FUNCTION

This function can be performed when the indicator is locked; must be in local mode. If the alarm is configured as a latched alarm (manual reset), alarm status is maintained even after the alarm condition stops.

Press **RESET** + either arrow (▲ or ▼) to reset both Alarm 1 and Alarm 2. The external contact, if enabled, resets both alarms. The rear terminal connections are Dig In + and -. The external contact works even if the indicator is in the remote mode.

8.2.5 PEAK HOLD FUNCTION

The following actions can be performed when the indicator is locked, and in either local or remote mode.

1. Monitoring Peak High and Peak Low

By pressing ▲ while the measured value is displayed, it is possible to monitor the peak high value. The decimal point at the right of the display will be lit steadily.

Press ▲ again to monitor the peak low value. The decimal point at the right of the display will now blink on and off.

Press ▲ to redisplay the measured value (normal operating mode).

Press **RESET + FUNC** to reset the peak high/peak low values and to restart for a new peak detection.



2. Hold-On Value

The external contact can be used to freeze input signal sampling, holding the last measured value for use on the display, alarms, retransmission etc. In this mode, the numerical value flashes on the display.

8.3 DEFAULT DATA LOADING PROCEDURE

In each one of the Indicator's three modes, configuration, calibration and operation, you can load default data to reset all of the parameters for that particular mode.

To load the default data:

Press ▼ + ▲, and once the display shows **dFOFF**, press ▲. When the display shows **dF On**, press **FUNC**. Default data will now be loaded. During data loading time the display will show **L.dAtA**.

The default data for the three modes are shown on the following pages.

Note: Certain default data will vary depending on the region the unit was sold.



8.3.1 DEFAULT DATA FOR CONFIGURATION PARAMETERS

Parameter	Description	Setting
A	Units	MPa
B	Decimal point position	None
B1	Full scale readout	70.0
C	Display filter time constant	400 mS
D	Input interrupt	High
E	Shunt calibration	Enable
E1	Shunt calibration value	80.0%
F	External contact function	Alarm manual reset
F1	Contact status	Closure
G	Alarm 1 operating mode	High with automatic reset
G1	Alarm 1 action	Reverse
G2	Alarm 1 masking option	Disable
G3	Alarm 1 filter	Off
G4	Alarm 1 hysteresis	1.0%
H	Alarm 2 operating mode	High with automatic reset
H1	Alarm 2 action	Reverse
H2	Alarm 2 masking option	Disable
H3	Alarm 2 filter	Off
H4	Alarm 2 hysteresis	1.0%
L	Analog retransmission type	4 - 20 mA (if fitted)
L1	Analog retransmission low scale value	0.00
L2	Analog retransmission high scale value	70.0
L3	Analog retransmission filter	Off

8.3.2 DEFAULT DATA FOR OPERATING PARAMETERS

Parameter	Description	Setting
1	Zero transducer calibration	0 mV
2	Full scale transducer calibration	33.3 mV
3	Tare calibration	0 mV
4	Alarm 1 threshold setting	40% of F.S.V.
5	Alarm 2 threshold setting	60% of F.S.V.
6	Keyboard status	Unlocked



8.3.3 DEFAULT DATA FOR CALIBRATION PARAMETERS

Default calibration parameters are provided to allow the user to verify that the instrument is working properly. They are not normally used as the final calibration values.

Caution: After default parameter loading, you should perform the proper indicator calibration procedure.



9. MAINTENANCE

9.1	Repair	32
9.2	Warranty	32

9.1 REPAIR

Questions concerning warranty, repair cost, delivery and requests for a RA# should be directed to the Dynisco Repair Department, 508-541-9400 or email: repair@dynisco.com. Please call for a return authorization number (RA#) before returning any product. Damaged instruments should be returned to:

Dynisco Instruments
 Attn: RA# _____
 38 Forge Parkway
 Franklin, MA 02038

Technical Assistance - Please call: 800-221-2201 or 508-541-9400 or fax 508-541-6206

9.2 WARRANTY

The 1380 Series of pressure indicators will provide excellent service and superior performance if proper care is taken during handling, installation, and use. This DYNISCO product is warranted under terms and conditions set forth in the DYNISCO web pages. Go to www.dynisco.com and click “warranty” at the bottom of any page for complete details.



10. TROUBLESHOOTING/ERROR MESSAGES

Diagnostics are performed at indicator start-up and during normal mode operation. If a fault condition is detected, the display will show the message **Er** followed by an error code. The following is a list of possible errors in numerical order.

Er 1

The alarm threshold values or transducer calibration (tare or zero) are out of limits or their values in memory are incorrect. The error may appear at instrument start-up in operating. After 3 seconds, the instrument will reset.

Simultaneously press ▼ and ▲ to load default data. Then load the desired threshold values and recalibrate the transducer.

Er 6

This error message appears during tare or zero transducer calibration if input value is greater than +/-25% of full scale calibration. The same error message appears during full scale calibration if the stored zero calibration value is greater than +/-25% of the new full scale calibration. In both cases the stored calibration value is not changed. This error message disappears automatically after 2 seconds.

Er 7

This error message appears during zero or full scale transducer calibration if a fault condition (hold-on value/overrange/underrange/input open) is found on an input signal or if the span value is not changed. This error message disappears automatically after 2 seconds.

Er 38

Error detected during EAROM read operation. This error may appear at instrument start-up in operating mode. This error message disappears automatically after 3 seconds, and the instrument will reset. If the error persists, return the instrument to Dynisco.

If this error appears during configuration/calibration, press **FUNC** or **RESET** to restart the procedure and then repeat operations. If the error persists, return the instrument to Dynisco.

Er 39

Error detected during EAROM write operation. This error may appear in operating mode when storing new value in EAROM (for example, alarm threshold or transducer calibration). The new values will be enabled but they will be lost when the instrument is powered down. This error message disappears automatically after 10 seconds.



If the error appears during configuration/calibration, press **FUNC** or **RESET** to restart the procedure and then repeat operations. If the error persists, return the instrument to your supplier.

Er40

This error occurs during an incomplete configuration save operation. The instrument had its power reset during a non-volatile ram write cycle. To clear, initiate the default data loading procedure and repeat the configuration and calibration procedure.

Er101

The configuration data stored in EAROM is wrong or inconsistent. This error may appear at instrument start-up in operating mode. This error message disappears automatically after 3 seconds. After that the instrument will reset.

If the error persists, enable configuration/calibration with the internal switch, load the default configuration data, and then perform a new configuration.

Er312

Error during internal autozero measurement for temperature drift compensation. The instrument repeats this check every 3 seconds. The analog retransmission and alarm go low scale or high scale as a failsafe configuration. If the error persists, return the instrument to Dynisco.

Er313

Calibration data fails checksum. To correct, initiate the default data loading procedure and recalibrate.

Er314

Instrument non-volatile memory un-initialized. Return to Dynisco.

Er315

Instrument non-volatile memory un-initialized. Return to Dynisco.

Er316

Instrument non-volatile memory un-initialized. Return to Dynisco.

Er317

Instrument non-volatile memory un-initialized. Return to Dynisco.



Erg00

ROM error. Return to Dynisco.

Erg01

RAM error. Return to Dynisco.

Erg02

Key stuck detected. Check domed buttons for damage.

Erg03

CPU fault. Return to Dynisco.

00000

Over-range indication.

This status is displayed when the A/D converter value is out of range, or the input signal is greater than full scale value plus 27% of span, or the displayed value exceeds the display capability of 9990.

-0000

Under-range indication.

This status is displayed when the A/D converter value is out of range, or the input signal is less than full scale value minus 27% of span, or the displayed value exceeds the display capability of -1990.

OPEn

This message is displayed when the instrument detects an open input on any one of the four or six transducer leads.

DyniscoLLC
 38 Forge Parkway
 Franklin, MA 02038
 USA

Tel: +1 508 541 9400
 Fax: +1 508 541 9436
 Email: Infolnst@dynisco.com

Dynisco Pressure Indicator NEW Model 1480	ALARM CONTACT	Transmission Output	Power supply voltage	1480 รุ่นใหม่ล่าสุด ผลิตภัณฑ์รุ่นเก่า OLD #1380, #1280
#14804100 1480-4-1-0-0	With 2 points 14804100	Volt , mA	85-264VAC	1380-2-3,1280-2-3 1380/2/3,1280/2/3
#14804100 1480-4-1-0-0	With 2 points 14804100	Volt , mA	85-264VAC	1380-1-3,1280-1-3 1380/1/3,1280/1/3
#14804100 1480-4-1-0-1	With 2 points 14804101	Volt , mA	22-65VDC	1380-2-1, 1280-2-1 1380/2/1, 1280/2-1
#14804000 1480-4-0-0-0	With 2 points	None	85-264VAC	

Dynisco Instruments S.a.r.l.
 466, rue du Marché Rollay
 94500 Champigny sur Marne
 France

Tel: +33 1 4881 8459
 Fax: +33 1 4881 8334
 Email: DyniscoFrance@dynisco.com

Dynisco.s.r.l.
 Via Adriatico, 2/2
 20162 Milano
 Italia

Tel: +39 02 661 01733
 Fax: +39 02 661 02908
 Email: Dyniscoltaly@dynisco.com

Dynisco UK Ltd.
 Unit 2B Crowood House
 Gipsy Lane
 Swinden NN2 8YY
 United Kingdom

Tel: +44 1527 577077
 Fax: +44 1527 577070
 Email: DyniscoUK@dynisco.com



Dynisco
 Service
24 HOURS A DAY
7 DAYS A WEEK
www.dynisco.com
 1-800-DYNISCO (US)
 00-800-DYNISCO-0 (Europe)